



In this issue: • 2018 Ford EcoSport+Apron Panel Repair • 2017 Lincoln Continental HUD Calibration • 2019 Ford Ranger  
• BASF Color Trends Q&A • Inside the Industry • I-CAR Training Class Update • Industry Events Calendar

## Importance of OEM Procedures and Parts Reinforced by Recent Testing

As more advanced technologies and newer materials become increasingly common in today's vehicles, the use of OEM repair procedures and parts that perform the same in a subsequent collision as those on the vehicle when it was made has become even more important.

In the wake of the John Eagle Collision Center case (see sidebar), Ford Motor Company asked an independent test lab to determine whether aftermarket copy versions of two F-150 parts frequently replaced in a collision repair would meet Ford dimensional design specifications, and the answer was a resounding "no."

The lab conducted laser scans of an aftermarket aluminum hood and several front bumper brackets for the 2012 F-150. The results show the non-OEM hood was not dimensionally compatible to Ford design specifications, with numerous substantial measurement deviations resulting in an uneven surface. As shown in the graphic below, peaks and valleys several millimeters outside of the Ford specification were found throughout the aftermarket copy part.

For the front bumper brackets, significant deviations

from Ford specifications were found with regard to guide-hole locations and their length, along with fluctuations in the curvature of the bracket wall in numerous areas.

"These variations are quite substantial," said Larry Coan, FCSD collision product manager. "Collision repair shops are able to work with very slight part variations, but not significant deviations like these that are off by several millimeters."

The significant variances found in this testing can lead to longer repair times and higher costs, and negatively impact the performance of the vehicle in a subsequent crash. "All components of the vehicle structure are designed and tested to work together in a real-world collision," said FCSD Collision Product Team Manager Lisa Fournier. "Any significant deviations from engineering specifications, such as changes in materials, forming processes, dimensional inaccuracies and any structural differences, along with how it is repaired, can dramatically alter the crash characteristics of a vehicle."

For more information on the importance of using the right parts and repair procedures, visit [Collision.Ford.com](http://Collision.Ford.com).

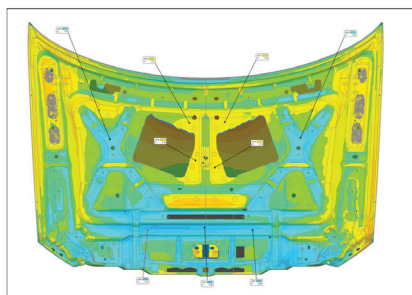
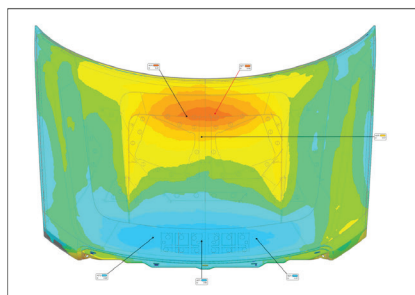

Degree of deviation (in millimeters): aftermarket copy vs. original Ford design

Significantly Lower      Meets Spec      Significantly Higher

## Aftermath of the John Eagle Collision Case

Following last year's \$31.5 million jury verdict against John Eagle Collision Center for its improper repair of a Honda Fit and the injuries its owners suffered in a subsequent collision, the plaintiffs' attorneys (Tracy Law Firm) commissioned a series of crash tests designed to show the potential impact of using non-OEM parts and repair procedures in a collision repair.

The firm reports 40-mph moderate-overlap frontal offset crash tests (replicating those regularly carried out by the Insurance Institute for Highway Safety) were conducted by Karco Engineering involving three Honda Fit vehicles: 1) an unaltered 2010 model; 2) a 2009 model that received the non-OEM-approved repair procedure (glued roof instead of welded) that was the focus of the case and an aftermarket windshield; and 3) a 2013 model repaired using OEM procedures but with several aftermarket parts—hood, radiator support, windshield, bumper reinforcement bar, left and right fenders, and left and right hood hinges (the 2009-2013 models are of the same structural design and considered identical for crash testing).

According to the Tracy Law Firm, the test results show the unaltered vehicle with original parts performed similarly to the Fit that earned a "Good" rating in its 2009 IIHS test. In contrast, the firm reports crash test dummies in both the vehicle using unapproved repair procedures and the one fitted with non-OEM parts saw their heads, necks, femurs and toes subjected to greater stress than in the unaltered vehicle, with significantly more seatbelt pass-through occurring in each.

The results serve to reinforce the importance of repairers researching and using OEM repair procedures every time, and that even slight changes in materials or deviation from proper procedures can have severe consequences.

## 2018 Expedition / Navigator Offer New Collision Repair Options

**Ford Senior Damageability Engineer Gerry Bonanni looks at some of the key repair procedures for the new aluminum-alloy vehicles.**

As the all-new 2018 Ford Expedition/Lincoln Navigator Series vehicles begin to reach collision repair facilities, repairers should notice a design similar to that of the F-150, which means repairs that are intended to be less-invasive, time-consuming and costly.

"The entire outer skin of the new 2018 Ford Expedition/Lincoln Navigator Series is comprised of 6022 aluminum alloy," said Bonanni, "which offers excellent corrosion resistance. Coupled with the all-new, high-strength steel frames, the new materials allow for a weight savings of up to 200 pounds on the Navigator and up to 300 pounds on the Expedition."

From a welding standpoint, Bonanni noted that this type

of alloy may be repaired utilizing 5554, 1.2mm aluminum wire, with pure argon as a shielding gas. A pulse-technology MIG-welder is also preferred by Ford.

"Unlike previous models, the A-pillar may now be serviced," informed Bonanni. "It can be sectioned right over the B-pillar reinforcement, using a butt-joint with

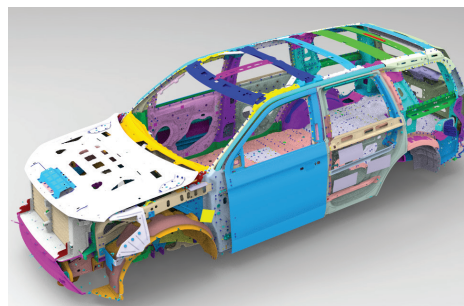

a backer." Specific details on this repair can be found in the official Ford workshop manual, Section 501-29: Side-Panel Sheet Metal Repairs.

Another repair the Expedition and Navigator borrow from the F-150 is the ability to section the B-pillar reinforcement, which now terminates before it reaches the roof skin panel, allowing for removal of the B-pillar without disturbing the roof. Simply cut a window into the exterior skin to gain access to the fasteners to properly remove the reinforcement. This modern procedure saves repairers the time and cost to remove the roof skin, front windshield and additional trim, possibly preserving what otherwise might have been a totaled vehicle.

One key repair difference is the center-floor crossmember. On the current F-150 and Super Duty this is a single-piece component design, and sectioning is allowed as part of this repair. On the 2018 Expedition and Navigator, however, the center-floor crossmember is a new, three-

## Ford Confirms the Return of Ranger

Looking to solidify its position as America's truck sales leader, Ford Motor Company recently confirmed the celebrated return of the Ranger mid-size pickup to the North American market.

The all-new 2019 Ford Ranger features a fresh exterior design, chassis and powertrain developed specifically for North American truck customers, and includes a high-strength steel frame, frame-mounted steel front-and-rear bumpers, and a 2.3-liter EcoBoost® engine mated to the only 10-speed automatic transmission in the segment.



Ranger comes in entry-level XL, mid-level XLT and high-level Lariat trim series with available Chrome and Sport appearance and FX Off-Road packages, and in two cab configurations: SuperCab and SuperCrew.

Ranger's twin-power dome hood houses its 2.3-liter EcoBoost® engine designed for efficiency and capability thanks to direct fuel injection, a twin-scroll turbocharger and 16-valve design. For added durability, the engine features a forged-steel crankshaft and connecting rods, and chain-driven dual overhead cams.

Ranger prioritizes ground clearance to help climb over off-road obstacles. The FX4 Off-Road Package provides additional trail capability with off-road-tuned shocks, all-terrain tires, a frame-mounted heavy-gauge steel front bash plate, frame-mounted skid plates and FX4 badging.

To give customers a great all-terrain driving experience, Ranger's FX4 Off-Road Package features an innovative Terrain Management System™—like that on the F-150 Raptor—while also introducing Ford's all-new Trail Control™ technology. Similar to cruise control for the highway, but designed for low-speed and rugged terrain, Trail Control takes over acceleration and braking, sending power and braking to each individual wheel to allow drivers to focus on steering while off-road.

Ranger also incorporates many smart driver-assist, passenger convenience and connectivity technologies: Automatic Emergency Braking is standard on all trim levels, while Lane Keeping Assist, Lane Departure Warning, a Reverse Sensing System and class-exclusive Blind Spot Information System with trailer coverage are standard on XLT and Lariat trim levels. Additional driver-assist technologies standard on Lariat include Pedestrian Detection and Adaptive Cruise Control.

Production of the 2019 Ranger begins late this year at Ford's Michigan Assembly Plant, and it is expected in showrooms in early 2019. Detailed repair-related information will be provided when it becomes available.

## 2018 Expedition / Lincoln Navigator Offer New Collision Repair Options

CONTINUED FROM PAGE 1

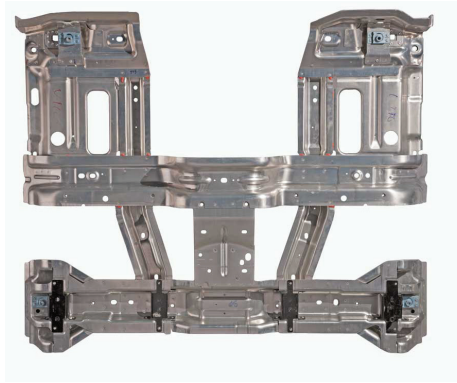

piece design and sectioning is not allowed. The outer edge of the center-floor crossmember may be replaced separately though in the event of a hard side-impact collision, utilizing the factory joints.

The new, high-strength steel frames for the vehicles are similar to that on the current F-150 and many frame-

sectioning repair kits offer repairers new found flexibility in tackling this repair. This includes a front, short-frame, stub-section kit (which runs about 18 inches from the front bumper to the factory joint), separately serviceable lower-control arm brackets, front- and rear-third frame-sectioning kits, and additional frame-service items such as bumper brackets, spring brackets and other specialty items.

"These offerings allow repairers to focus on only the damaged portion(s) of the frame, creating a less-invasive overall repair plan and allowing for yet another option to prevent a vehicle from being totaled," concluded Bonanni.

More information on the 2018 Expedition and Navigator is available at [OEMISStop.com](http://OEMISStop.com), with detailed repair procedure walk-throughs now available on [Motorcraftservice.com](http://Motorcraftservice.com).

For any additional repair-specific questions on the Expedition, Navigator—or any other Ford or Lincoln vehicles—contact Gerry Bonanni at (313) 317-9000 or the Ford Crash Parts Hotline at [cphelp@fordcrashparts.com](mailto:cphelp@fordcrashparts.com)

## Feature Vehicle: 2018 Ford EcoSport



The all-new 2018 Ford EcoSport is the latest addition to Ford Motor Company's impressive lineup of utility vehicles, and signals its entry into the rapidly growing Subcompact Utility segment. The EcoSport—which arrived in dealerships early this year—gives buyers who are looking for a subcompact SUV exactly what they want: fun, capability and the feeling of being connected. EcoSport offers these things and so much more, giving owners the freedom and flexibility to pursue their active lifestyles.

Here are some important details on the 2018 EcoSport, followed by valuable information on the vehicle's front-apron repair procedure (on page 3).

### Available Engines

- 1.0L EcoBoost I-3 (123 horsepower @ 6,000 rpm, 125 lb.-ft. of torque @ 3,500 rpm)
  - 1,400 lbs. of towing capability
- 2.0L EcoBoost I-4 (166 horsepower @ 6,500 rpm, 149 lb.-ft. of torque @ 4,450 rpm)
  - 2,000 lbs. of towing capability

### Power and Handling

- 6-speed SelectShift® Automatic Transmission
- Auto Start-Stop Technology
- Torque Vectoring Control
- Intelligent 4WD (standard on 2.0L engine)

### Safety and Security

- 10 standard airbags
- AdvanceTrac® with RSC® (Roll Stability Control™)
- Traction control
- Wiper-activated headlamps
- MyKey®
- Rear-view camera
- SecuriLock® Passive Anti-Theft System
- SOS Post-Crash Alert System™

### Body

- High-strength, low-alloy (HSLA), high-strength, ultra-high-strength (UHSS) and mild steels
- Roof outer-panel constructed of mild steel
- Steel hood
- Steel luggage compartment lid
- Body-side outer panels constructed of mild steel
- DP (dual-phase) steel in select body-structure components
- Bolted, removable front fenders, hinged doors and hood
- Dent-resistant steel fenders
- Ultra-high-strength steel rear bumper beam
- Front- and rear-subframe assemblies housing suspension and steering components
- Underbody components constructed of mild, dual-phase and high-strength steels
- Mastic pads used on floor pan for sound deadening

# Official Repair Procedures: 2018 Ford EcoSport Fender Apron & 2017 Lincoln Continental Head Up Display Module

As part of our ongoing effort to help repairers make the proper repair the first time, we present another series of repairs straight from the official Ford Workshop Manual. This time we look at the repair of the front fender apron

panel reinforcement for the all-new 2018 Ford EcoSport, followed by the removal and calibration for the head up display module on the 2017 Lincoln Continental.

Please note that the following illustrations are intended

as a general guideline and are not all-inclusive. For more in-depth repair information on this and other Ford and Lincoln vehicles, consult the Ford Workshop Manual, which can be found at [Motorcraftservice.com](http://Motorcraftservice.com).

## 2018 Ford EcoSport Fender Apron Panel

### Special Tools / Equipment / Materials

- Resistance spot-welding equipment
- Spherical cutter
- 8mm drill bit
- MIG/MAG welding equipment
- Spot-weld drill bit
- Locking pliers

**NOTE:** The fender apron panel reinforcement is made of DP600-class steel and may be sectioned, following Section 501-26: Body Repairs—Vehicle Specific Information and Tolerance Checks, General Procedures. The following repair procedure assumes full-component replacement.

### Removal

1. De-power the SRS (refer to Section 501-20B: Supplemental Restraint System—General Procedures).
2. Remove the following vehicle components:
  - a. Hood (refer to Section 501-02: Front End Body Panels—Removal and Installation).
  - b. Headlamp (refer to Section 417-01: Exterior Lighting—Removal and Installation).
  - c. Battery (refer to Section 414-01: Battery, Mounting and Cables—Removal and Installation).
  - d. Front bumper (refer to Section 501-19: Bumpers—Removal and Installation).
  - e. Fender (refer to Section 501-02).
  - f. Cowl vent screen and cowl panel (refer to Section 501-02)
  - g. Front sail glass (refer to Section 501-Glass, Frames and Mechanisms General Procedures).

3. Restore the vehicle to pre-accident dimensions, if required (refer to Section 501-26: Body Repairs—Vehicle Specific Information and Tolerance Checks, Description and Operation).

**NOTE:** Left-hand side of vehicle shown; right-hand side similar.

4. Using the spot-weld drill bit and the spherical cutter, remove the welds. (Fig.1)

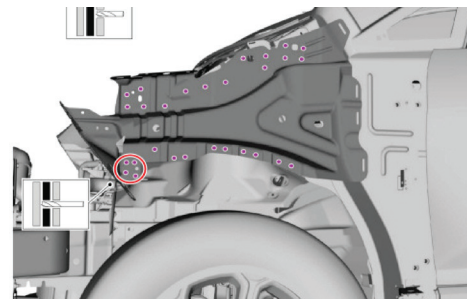

(FIG. 1)

5. Open the retaining tabs and remove the fender apron reinforcement outer panel. (Fig.2)

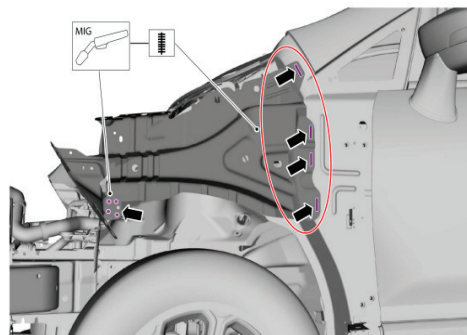

(FIG. 2)

### Installation

1. Install and properly position and clamp the new panel into position using the locking pliers.
2. Using the 8mm drill bit, drill plug-weld holes. (Fig.3)

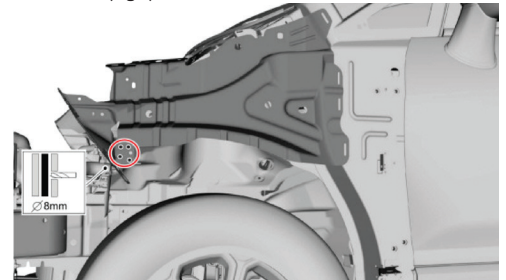

(FIG. 3)

3. Using the MIG/MAG welding equipment and the resistance spot-welding equipment, install the welds. (Fig.4)

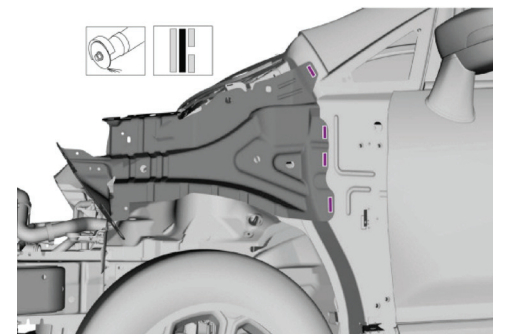

(FIG. 4)

4. Refinish the entire repair area utilizing a Ford-approved paint system.
5. Restore vehicle corrosion protection (refer to Section 501-25: Body Repairs General Information, General Procedures).
6. Install the previously removed vehicle components in reverse order.
7. Power-up the SRS System (refer to Section 501-20B).

**For additional questions,**  
contact Ford Senior  
Damageability Engineer  
Gerry Bonanni  
at (313) 317-9000 or  
Ford Crash Parts Hotline:  
[cphelp@fordcrashparts.com](mailto:cphelp@fordcrashparts.com)

## 2017 Lincoln Continental Head Up Display (HUD) Module

### Removal

**NOTE:** Removal steps in this procedure may contain installation details.

1. Remove the push-pins and the left-hand-side lower instrument panel.
2. Remove the bolt and disconnect the HUD electrical connector (torque: 89 in./lbs. or 10Nm).
3. Remove the windshield (refer to Section 501-11: Glass, Frames and Mechanisms – General Procedures).
4. Remove the instrument panel upper section (refer to Section 501-112: Instrument Panel and Console – Removal and Installation).
5. Remove the light sensor (refer to Section 417-01: Exterior Lighting – Removal and Installation).
6. Release the clips and remove the defroster grille. (FIG. 1)

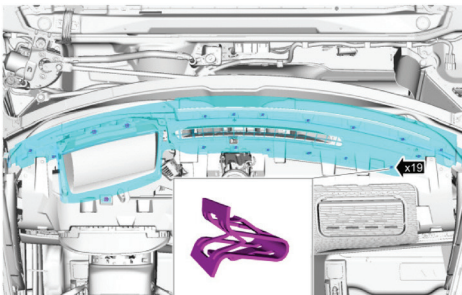

(FIG. 1)

7. Remove the bolts and the HUD module (torque: 89 in./lbs. or 10Nm). (FIG. 2)

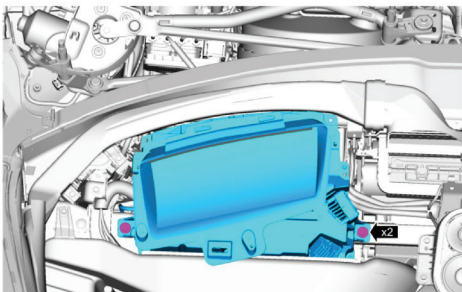

(FIG. 2)

8. To install, reverse the previous steps.
9. Carry out adjustments/calibration for the HUD module display (refer to Section 419-03B: Collision Warning and Collision Avoidance System – General Procedures).

### Positional Calibration

1. With brake pedal in the rest position, press the start button.
2. Select and press the HUD button, located on the steering wheel.
3. The instrument panel menu will appear in the message center; press OK.
4. Ensure the HUD is selected as: ON.
5. With the brake pedal now pressed, start the vehicle.
6. Select the BRIGHTNESS adjustment mode.
7. Set the HUD brightness to 13 and press OK.
8. Select the HUD position menu and press OK.
9. Select vertical position and press OK.
10. Move the vertical setting to the lowest position by repeatedly selecting the down position on the control switch.
11. Vertically center the HUD by selecting the UP position on the control switch SIX times; press OK.
12. Select horizontal position and press OK.
13. Move the horizontal setting to the LEFTMOST position by repeatedly selecting the DOWN position on the control switch.
14. Horizontally center the HUD by selecting the UP position on the control switch SIX times; press OK.
15. Select image rotation and press OK.
16. Move the rotational setting to the most counter-clockwise position by repeatedly selecting the DOWN position on the control switch.
17. Rotationally center the HUD by selecting the UP position on the control switch SIX times; press OK.
18. Press the OK button again to exit out of menu.
19. Turn vehicle off.

*On Target* plans to include more repair information specific to HUD calibration in future issues, focusing on distortional calibration, warping compare and service calibration reset.

## I-CAR Unveils New Classes; Training Increased in 2017

Attempting to help the industry keep up with the increasingly complex and rapidly changing technology and materials in today's vehicles, I-CAR (the Inter-Industry Conference on Auto Collision Repair) has recently introduced 10 new vehicle- and technology-specific training courses. Along with the 2018 Ford Expedition and Lincoln Navigator aluminum body repair course ([FO007E01](#) – detailed in the last issue of *On Target*), the new classes focus on topics such as: camera calibration, inspection and initialization; blind spot and parking assist systems calibration; steering angle sensors; windshield and advanced driver assist systems using OEM repair procedures; and others.

To help give repairers some insight into the value of the new training, I-CAR and the Society of Collision Repair Specialists recently teamed up for a two-part video series examining the courses. Those are available for viewing at [SCRS.com](#), while repairers can register for the new classes at [I-CAR.com](#).

Meanwhile, I-CAR reports it saw significant training increases in 2017, with nearly 84,000 students completing courses. It says the number of Gold Class shops in the U.S. now stands at 5,570.



[www.FordCrashParts.com](http://www.FordCrashParts.com)

# BASF Color Trends Detailed: Q&A with Color Design Excellence Group Director Paul Czornij



**OT:** What kind of research and in-depth analysis was performed in creating the 65 new colors? How long did it take?

**PC:** We researched trends over a long period of time, looking at both visual, sensual and more abstract sources. We then look to put these into buckets of ideas or activities that may eventually be a trend driver. Our BASF design studios—in four different locations around the globe—do that type of work on a local level, and then we all come together and share our findings to develop the global themes and trend signals. As these come together, we look for color directions and textures that are used as a basis for color proposals. These are then worked into our BASF Coatings technology and applied onto substrates that define our understanding of these trends into automotive colors.

**OT:** How are the 65 colors divided up worldwide?

**PC:** The regions of Asia-Pacific, North America, and EMEA (Europe, Middle East and Africa) all contribute 20 colors, with an additional five that capture the essence of trends in China.

**OT:** What is some of the technical background related to structured textures?

**PC:** Most of the colors we create are the so-called “metallic” colors. These contain the flaked, special-effect pigments that add sparkle or a color shift or shimmer. We try to use our understanding of texture to support the selection of effects to generate the color.

**OT:** *Undercurrent Blue* utilizes in-use pigmentation technology. To what extent was that important in the creation of this color? How are new/different colors/shades created utilizing standard technology? To what extent do new colors rely on new technology?

**PC:** We have a diverse set of designs, each uniquely developed to meet the design intent on color and texture related to the trend theme. We use colorants and effects to meet the intent of the brief. If there is a new effect that can get us into a new, aesthetically-pleasing color space, we may strongly consider formulating with it.

**OT:** Concerning the three new North American colors, will there be any variations available to automakers?

**PC:** BASF’s desire is to make our customers successful, so we are very open to discussing and partnering with them to meet their specific coloristic needs, brand strategies and performance criteria.



**OT:** Did the unique demands of reparability factor into the creation of the colors?

**PC:** As we move into newer color spaces, the reparability factor is challenging, so we try to ensure the technology can meet the specific requirements needed for feasibility. We remain interested in working with our customers on all aspects of color.

**OT:** Several surveys continue to indicate that white remains the most popular vehicle color, yet the top three colors for North America are darker colors. What went into that decision?

**PC:** Color popularity is a real-time snapshot, and what we do with color trends is create possibilities for future color designs for cars. If we can unleash creativity we can expand the limits of color styling for the future. We also understand the importance of black, white, and silver/gray, so we are very active in innovating in these spaces as well.

**OT:** Do the new paints/pigments work across multiple substrates, such as HSS, UHSS, aluminum alloy and carbon fiber?

**PC:** BASF looks to ensure the engineering specifications for performance for each of the colors will be met. Sometimes this is a complex and detailed focus and needs careful testing.

**OT:** Moving forward, what aspect of automotive paints/pigmentation do you think will have the most impact in the years to come?

**PC:** As the trends toward alternate transportation continue to evolve, the functional performance of the paint must remain up to the task. In this sense, colors will be increasingly functional in scope. That doesn’t necessarily mean colors will be less attractive, only that color positions will be seen in a new context. Pigments and coatings will have to address these requirements accordingly.

Very special thanks to Paul Czornij and Jeff Wildman, BASF manager OEM & industry relations, for their hospitality. For more information on BASF, Jeff can be contacted at [jeffrey.wildman@basf.com](mailto:jeffrey.wildman@basf.com)

In the last issue of *On Target* (available at [OEMIStop.com](http://OEMIStop.com)), we reported on BASF’s unveiling of 65 new automotive color trends—collectively entitled *Translucid*—including the top three new colors for the North American market: *Undercurrent Blue*, *Abyss*, and *Cabocho*.

As promised, *On Target* was able to sit down with Paul Czornij, head of design for BASF’s Color Design Excellence Group to discuss the color trends in more detail:

**On Target:** The theme behind *Translucid* is a desire to break away from technology’s encroachment on our daily lives. Was that deliberately chosen to act as a counterpoint to the automotive industry itself, which has become much more reliant on technology, especially within the last few years regarding safety, driver-assistance and entertainment systems?

**Paul Czornij:** It’s more related to the human need for balance. For sure, technology is important and has improved the human condition, but we need to retain the connection to basic human aspirations. We want more clarity, transparency and reliability from everything, including the way we use cars. So, we always consider the automotive world in addition to other, non-automotive aspects and how they shape our lives. In that sense, we mention the “hands-off independence” of how autonomous driving changes our notions of simple driving pleasures—hands on the steering wheel, foot to the gas pedal, and the like.



**Inside the Industry**

**Monthly Webinars on Finding OEM Procedures**

Well known industry consultant and trainer Mike Anderson has announced he'll be offering free monthly webinars throughout the year on how to find OEM-specific repair information. The webinars will focus on one automaker each month, and will include navigation through each OEM repair information website and the opportunity to submit questions for that particular OEM. Go to [CollisionAdvice.com](http://CollisionAdvice.com) for more information.

**Case Linked to *Avery v. State Farm* Continues**

A U.S. District court has denied State Farm's request to dismiss the class-action lawsuit linked to its alleged actions in attempting to reverse the infamous *Avery v. State Farm* aftermarket parts case in the early 2000s. The plaintiffs in *Hale et al v. State Farm* claim the insurer secretly recruited Judge Lloyd Karmeier,

then provided the bulk of campaign funding in his successful run for the Illinois Supreme Court. Judge Karmeier was the deciding vote in the state Supreme Court's 2005 decision to overturn the \$1.05 billion *Avery* ruling. The current suit is seeking \$7.6 billion in damages.

**Auto Insurance Hits New High**

Auto insurance premiums in the U.S. have hit a new all-time high. That's according to insurance search engine [TheZebra.com](http://TheZebra.com), which reports annual premiums are up 20 percent since 2011, and now average \$1,427 nationwide.

**Collision Repair History – Stories Wanted!**

A collision industry veteran is in the midst of writing the history of the collision repair industry, and he's looking for stories and photos from shops around the country. Gary Ledoux, author of several books on the history of the Old West, is asking shops to submit material for possible inclusion in the book, particularly

those that have been in business since at least the 1940s. Submissions can be made through his website at [Yesterwreck.com](http://Yesterwreck.com). The book is due out late this year.

**Collision Repair Legislation**

With many state legislatures under way for 2018, several are already considering collision repair-related measures:

- CA – A 1679 – Died in committee. Would have overturned recently enacted anti-steering and labor rate regulations.
- HA – H 1620/S 2243 – Would drop the current requirement for consumers to pay out-of-pocket for any price difference for OEM parts.
- IA – H 529 – Anti-steering measure.
- IN – S 164 – Anti-steering measure.
- MO – H 1444 – Would repeal state's vehicle safety inspection program.
- WV – S 308 – Would allow only new OEM parts for vehicle's first three years.

**2018 Industry Events Calendar**

Apr. 5	<a href="#"><u>AASP-MN Annual Meeting and Leadership Conference</u></a>	Bloomington, MN
Apr. 10	<a href="#"><u>SCRS Board of Directors Meeting (Open)</u></a>	Westminster, CO
Apr. 11-12	<a href="#"><u>Collision Industry Conference General Meeting</u></a>	Westminster, CO
May 2 - 6	<a href="#"><u>Automotive Service Association Annual Meeting</u></a>	Orlando, FL
June 1	<a href="#"><u>Auto Glass Safety Council Training and Certification</u></a>	Bellevue, WA
Aug. 6	<a href="#"><u>Collision Repair Education Foundation Annual Golf Outing</u></a>	Dacula, GA
Aug. 7 - 8	<a href="#"><u>Collision Industry Conference General Meeting</u></a>	Atlanta, GA
Aug. 8 - 10	<a href="#"><u>NACE Automechanika</u></a>	Atlanta, GA
Sept. 27 - 29	<a href="#"><u>Auto Glass Safety Council Auto Glass Week™</u></a>	San Antonio, TX
Sept. 29	<a href="#"><u>Auto Glass Safety Council Training and Certification</u></a>	San Antonio, TX
Oct. 30	<a href="#"><u>Collision Industry Conference General Meeting</u></a>	Las Vegas, NV
Oct. 30 - Nov. 1	<a href="#"><u>Automotive Aftermarket Products Expo (AAPEX)</u></a>	Las Vegas, NV
Oct. 30 - Nov. 2	<a href="#"><u>Specialty Equipment Market Association (SEMA) Show</u></a>	Las Vegas, NV
Oct. 31 - Nov. 3	<a href="#"><u>ATRA Powertrain Expo</u></a>	Las Vegas, NV

**2019**

Jan. 16 - 17	<a href="#"><u>Collision Industry Conference General Meeting</u></a>	Palm Springs, CA
--------------	--	------------------

**SHARE YOUR THOUGHTS**

The purpose of **On Target** is to provide Ford and Lincoln dealership parts departments and independent collision repair shops with the general and technical information needed to deliver efficient, high-quality repairs to Ford, Lincoln and Mercury vehicle owners. In addition, information on parts wholesaling policies and procedures, and collision repair industry activities will also be featured.

**On Target** is scheduled to be published three times a year.

Your comments and article ideas are welcome.

You can e-mail **On Target** at: [cphelp@fordcrashparts.com](mailto:cphelp@fordcrashparts.com).

Additional copies of **On Target** are available on the home page on [FMCDealer.com](http://FMCDealer.com). Independent collision repair shops should contact their Ford or Lincoln wholesaling dealer.

**On Target** is also available free of charge by clicking on the Ford page at [OEMIStop.com](http://OEMIStop.com).

**On Target**

Produced for Ford and Lincoln wholesaling dealers and their collision repair customers.

**Editor**  
Adam Gair

**Contributors**  
Chris Caris  
Kim Jennings  
Steven Lubinski  
Andrea Presnell



FORD PARTS

Dealership Information

# Crash Parts Order Form

Use this form to provide us with the information necessary to make certain we deliver the right parts on time ... the first time!

The information below can be found on the certification label located on the driver's-side door jamb.

If the vehicle is damaged in this area provide us with the Vehicle ID# located on the driver's-side front corner of the dashboard.

<b>VEHICLE ID#</b>	(Need all 17 Digits)				
<b>TRIM CODE</b>		<b>YEAR</b>		<b>DAMAGE AREA (Circle)</b>	
<b>MLDG. CODE</b>		<b>MAKE</b>		FRONT	REAR
<b>BODY CODE</b>		<b>PHONE:</b>	( )	LEFT SIDE	RIGHT SIDE
<b>CONTACT:</b>		<b>SHOP:</b>		UNDERBODY	LEFT / RIGHT

## 2018 FORD ECOSPORT

Date Ordered:	<b>PARTS ORDER</b>	Date Needed:
---------------	--------------------	--------------

QUANTITY	PART NUMBER / PART DESCRIPTION

**NOTE: Refer to vehicle diagrams for part identification and numbers.**

### Front Bumper

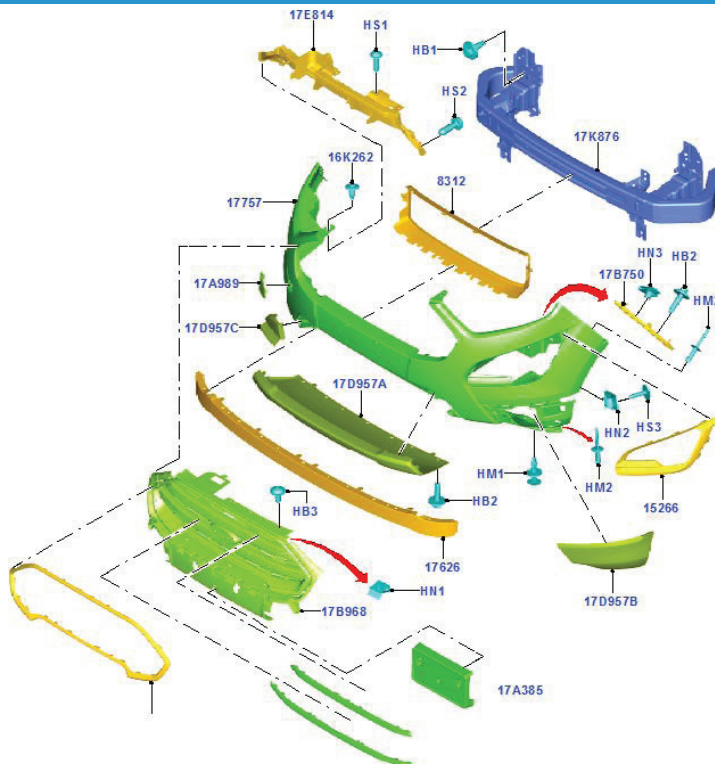

### Front Apron

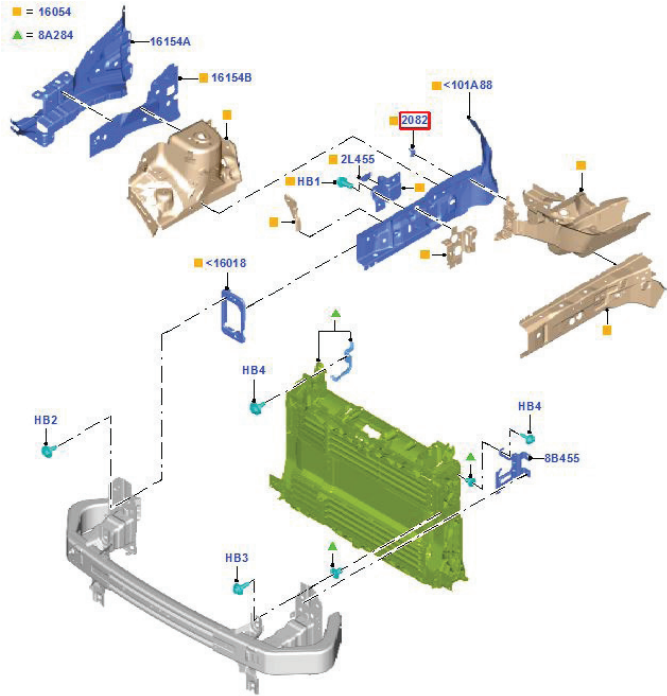

### Hood

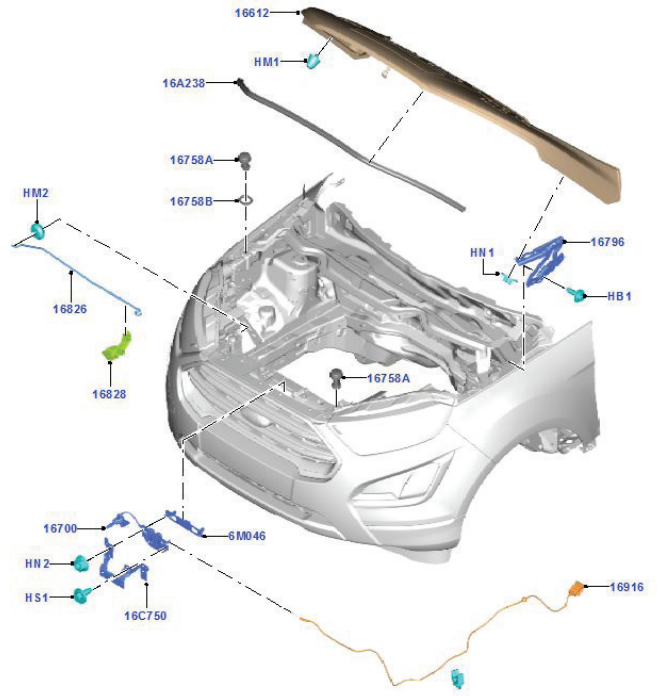

### Front Floor Pan

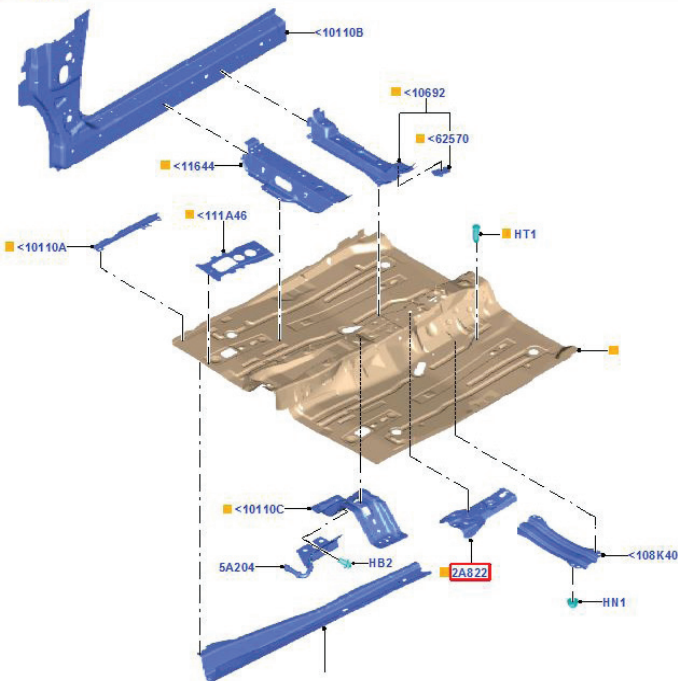

### Rear Bumper

